

## Mobile Generator – MMG100 Specifications

### ENGINE

- John Deere® PE4045HF285 - turbocharged, diesel engine
  - Prime - 122 hp @ 1800 rpm
  - Standby - 133 hp @ 1800 rpm
  - 4 cylinder
  - 4.5 L displacement
  - Tier III approved
- Steel, single wall fuel tank
  - 147 gal. capacity
  - 22 hr. run time – full load
  - Fuel tank built into skid of generator set
- Fuel consumption at prime:
  - 100% - 6.2 gph (23.5 Lph)
  - 75% - 4.7 gph (17.8 Lph)
  - 50% - 3.1 gph (11.7 Lph)
- Cooling system capable of operating at 120°F ambient
- Low coolant shutdown
- Radiator and oil drains plumbed to exterior
- Rubber vibration dampers isolate engine/generator from frame
- Disposable air filter - paper element
- Air filter restriction indicator mounted on control panel
- 60 Hz engine/generator
- Electronic isochronous governing

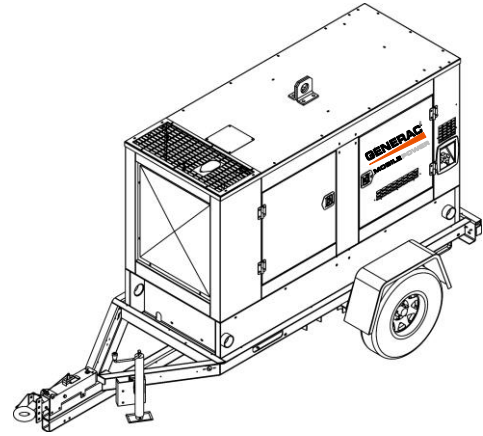

### GENERATOR

- Marathon Electric®
  - Brushless
  - 4 pole
  - Class H insulation
- Voltage regulation +/- 1% with Marathon SE350 Voltage Regulator

### SYSTEM OUTPUT

- 3 selector switch modes:
  - Single phase – 120 / 240V Zig Zag
  - Three phase – 120 / 208V Low Wye
  - Three phase – 277 / 480V High Wye
- 75 kW / 75 kVA – standby, single phase
- 71 kW / 71 kVA – prime, single phase
- 86 kW / 107 kVA – standby, three phase
- 78 kW / 98 kVA – prime, three phase

### SYSTEM CONTROLS

- Power Zone™ controller and display
  - Backlit, 800 x 480 pixel resolution color display
  - -40°F to 185°F operating temperature range
  - Automatic coarse voltage adjustment
  - Integrated fine voltage adjustment

- PLC functionality
- Push buttons for easy operation
  - Manual or Auto Start
  - Engine Start
  - Engine Stop/Reset
  - Alarm Mute
  - Operator Screens
    - ◆ Home
    - ◆ Engine
    - ◆ Generator
    - ◆ Voltage Adjust
  - Scrolling Arrows for Diagnostic Information
    - ◆ Engine diagnostic display
      - Oil pressure
      - Engine temperature
      - Fuel level
      - Battery
      - Aftertreatment inlet/outlet temperature
      - Ash/soot levels
    - ◆ Generator diagnostic display
      - System kW output display
      - Line output & frequency display
    - ◆ Alarms
      - Warning
      - Shutdown
      - Electrical Trip
      - Engine
    - ◆ Alarm list – warnings / shutdowns 250 event history log – date/time stamp
      - Fuel level: warning – 15%; shutdown – 5%
      - Overspeed protection: shutdown – 115%
      - Oil pressure: warning – 25 psi; shutdown – 20 psi
      - Coolant temperature: warning – 220°F; shutdown – 230°F
      - Battery voltage: over – 15VDC; under – 11VDC
      - Generator over voltage: warning – 110%; electrical trip – 111%
      - Generator under voltage: warning – 87%; electrical trip – 86%
      - Generator over frequency: warning – 105%; electrical trip – 110%
      - Generator under frequency: warning – 95%; electrical trip – 90%
      -
    - ◆ Inputs/Outputs
    - ◆ Auto Schedule
    - ◆ Status
    - ◆ Configuration of controller, firmware and connections

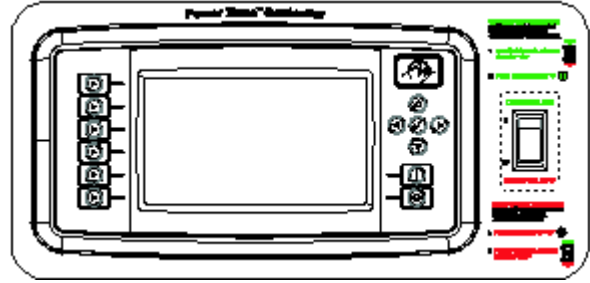

## ELECTRICAL CONTROLS

- Remote start / stop contacts located next to lug box
- Lockable control box door with diagnostics window
- Lockable lug box with safety switch
  - Trips main breaker when lug door is opened
  - Disables voltage regulator
- Cable entry guides to the lug box
  - Restricts access of foreign objects
- Output ground connection lug inside lug box

- 400A main breaker with shunt trip
- Convenience receptacles with individual breakers (restricted use in high wye mode)
  - (2) 120V 20 Amp GFCI duplex outlets (Nema 5-20R type)
  - (3) 125 / 250V 50 Amp, 3 pole, 4 wire twistlock (Non-Nema 6369)
- Panel mounted rheostat for voltage adjustment - +/- 10%
- 720 CCA wet cell battery

## ENCLOSURE

- Generac Mobile Power decals
- Aluminum, sound attenuated enclosure
  - UV & fade resistant, high temperature cured, white polyester powder paint
  - Insulated and baffled
  - 68 dB(A) at 23 feet – prime power
- Fully lockable enclosure including doors and fuel fill
- Stainless steel hinges on doors
- Emergency stop switch located on outside of enclosure
- Central lifting point
- Multi-lingual operating/safety decals
- Document holder with operating manual including AC/DC wiring diagrams

## TRAILER

- DOT approved tail, side, brake, and directional lights
  - Recessed rear lights
- Transportation tie downs
- Safety chains with spring loaded safety hooks
- 3" lunette ring hitch
- 6000 lb. axle with surge brakes
- 3000 lb. tongue jack with footplate
- ST225/75R15 tubeless tires – 8 ply

## WEIGHTS & DIMENSIONS

### Skid mounted

- Dry weight: 3402 lbs (1543 kg)
- Operating weight: 4361 lbs (1978 kg)
- 96 x 38 x 62 in  
(2.44 x 0.97 x 1.58 m)

### Trailer mounted

- Dry weight: 4104 lbs (1860 kg)
- Operating weight: 5062 lbs (2296 kg)
- 158 x 60 x 84 in  
(4.01 x 1.52 x 2.13 m)

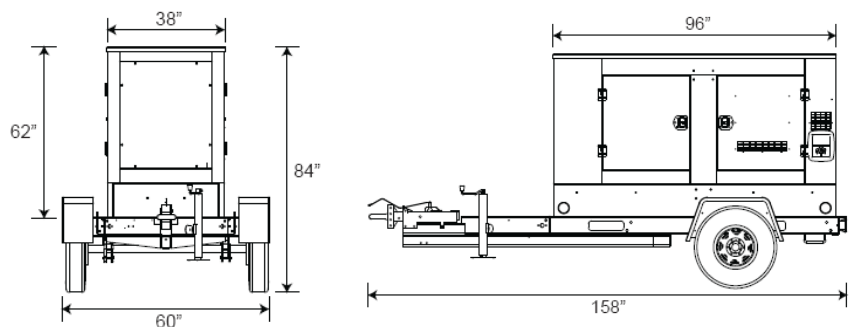

## WARRANTY

- Engine and generator covered under OEM warranty – consult factory for details.

## CERTIFICATIONS

- CSA certified

---

## MMG100 Options

### ENGINE OPTIONS

- ◆ In-line engine block heater (Kim Hotstart)
- ◆ Fuel transfer pump

### ELECTRICAL CONTROLS OPTIONS

- ◆ 720 CCA AGM battery
- ◆ Battery disconnect
- ◆ Battery charger – 2A trickle

### GENERATOR OPTIONS

- ◆ PMG Generator - critical grade power quality
- ◆ SUPERSTART™ Generator - motor starting applications
  - 78 kW / 78 kVA – standby, single phase
  - 72 kW / 72 kVA – prime, single phase
  - 88 kW / 110 kVA – standby, three phase
  - 80 kW / 100 kVA – prime, three phase

### VOLTAGE OUTPUT OPTIONS

- ◆ 4 position phase switch
  - Single phase – 120 / 240V Zig Zag
  - Three phase – 120 / 208V Low Wye
  - Three phase – 277 / 480V High Wye
  - Three phase – 120 / 240V Delta
- ◆ Dedicated voltage configurations
- ◆ Buck Transformer kit - Provides 120V at GFCI outlets when in 277/480V
- ◆ Cam locks

### SYSTEM CONTROLS OPTIONS

- ◆ Analog gauges
- ◆ Auxiliary strobe/audible indication for soft & hard alarm conditions

### COOLANT OPTIONS

- ◆ 60/40 Coolant - cold weather applications

### ENCLOSURE OPTIONS

- ◆ Fire extinguisher
- ◆ Interior cabinet light

Control panel light

## **FUEL TANK OPTIONS**

- ◆ 36 hr. single wall fuel tank (requires tandem axle trailer)
- ◆ 17 hr. double wall fuel tank
- ◆ 120% Containment

## **TRAILER OPTIONS**

- ◆ Single axle trailer w/ electric brakes
- ◆ Tandem axle trailer w/ surge brakes
- ◆ Tandem axle trailer w/ electric brakes
- ◆ 6 pin or 7 spade electrical connectors
- ◆ Spare tire/wheel kit

## **HITCH OPTIONS**

- ◆ 2" ball
- ◆ 2 5/16" ball
- ◆ Adjustable height options:
  - 2" ball
  - 2 5/16" ball